

BF4-IR2 Series

# Active Optical I/F Connector

**BF4-IR2** Series

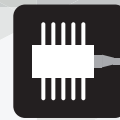

AOC



Low Power



Noise Prevention

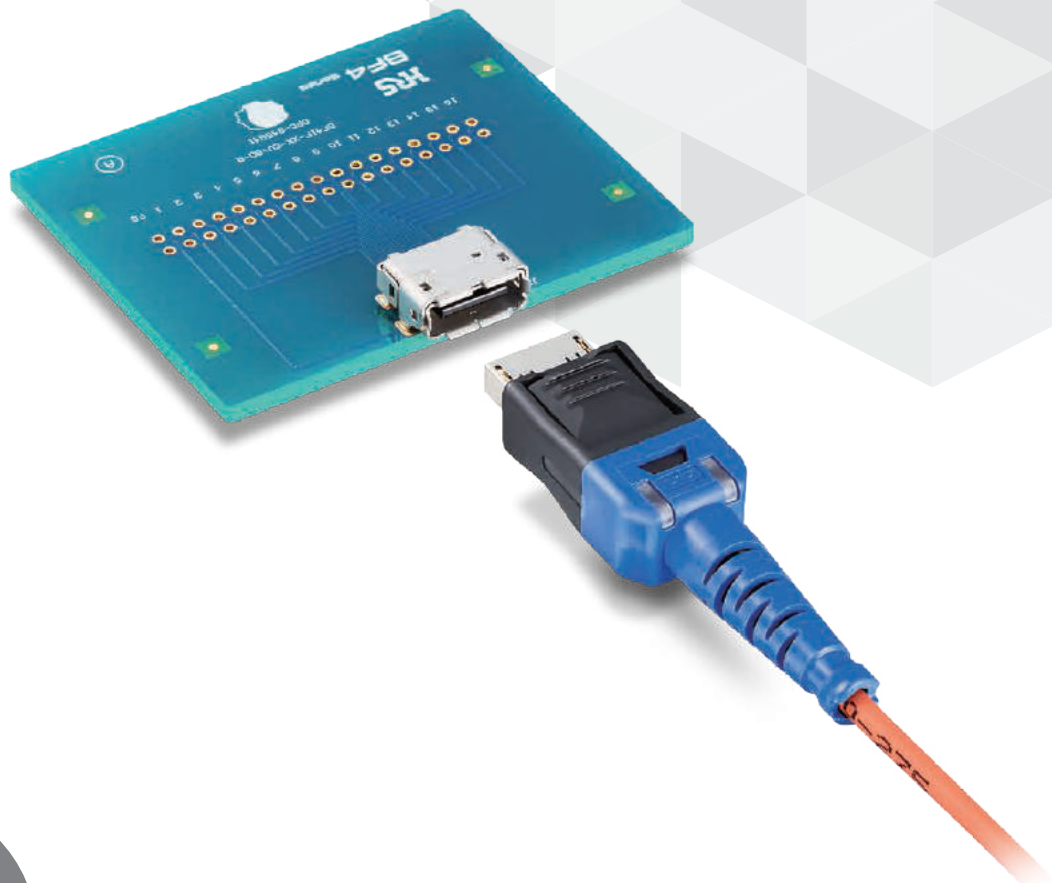

NEW

## Outline

The bidirectional transmission active optical connector BF4-IR2 has been developed for internal and inter-device wiring. Incorporating two BF4MC Series connectors inside the plug enables bidirectional transmission, significant lower use of power consumption than conventional optical transmission modules, and an interface with flexibility superior to conventional optical fiber cables. Furthermore, BF4-IR2 is a dual core optical I/F connector that allows long distance transmission, electromagnetic noiselessness and isolation, all of which are merits of optical transmission.

\* Refer to the BF4-IR2 Series Design Note (ETAD-K0794) and BF4MC Series Design Note (ETAD-K0671) for basic operation.

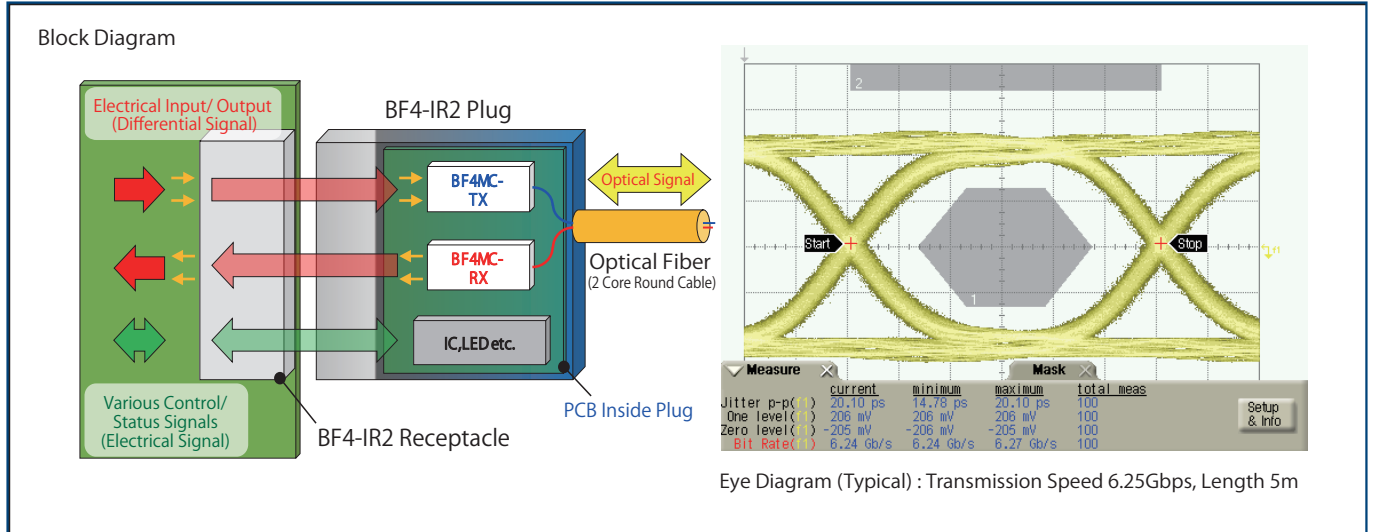

## Features

### 1. Mating Durability of 1,000 Cycles

Unlike conventional optical connectors, the BF4-IR2 Series is an active connector (electrical connection) and has a robust design for a mating durability of up to 1,000 cycles like other Hirose interface connectors.

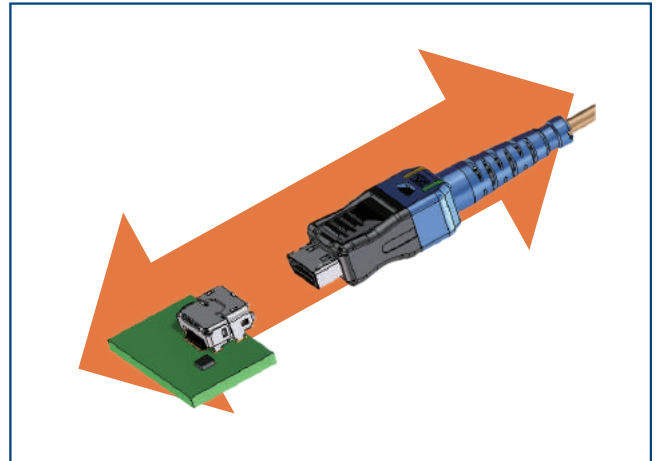

### 2. Built-in LED for Connection Confirmation

The built-in LED (Amber/Green) allows for operation check (control confirmation) from outside the connector.



### 3. Bending Durable 2 Core Fiber

BF4-IR2 uses the same flexible fiber as BF4MC. The minimum recommended bending radius is R10.

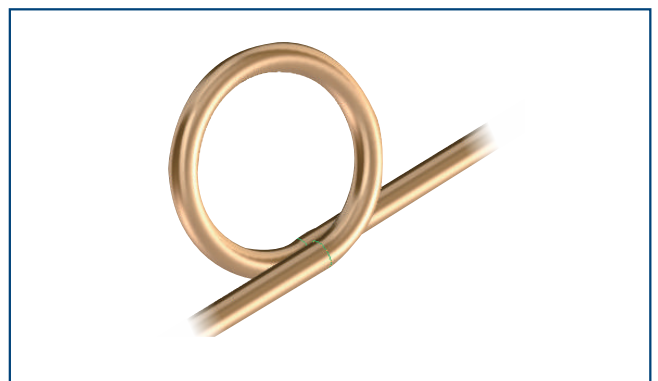

## 4. Low Power Consumption

Two BF4MC inside the BF4-IR2 enable low power consumption.

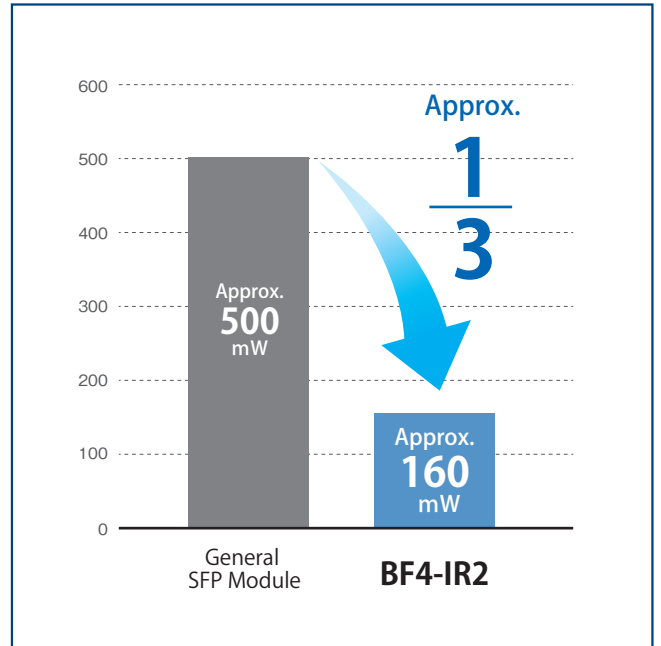

## Electrical Characteristics

BF4-IR2 Plug Electrical Properties	Min.	Nominal	Max.	Unit	Remarks
Transmission Speed (8B10B)	0.05	-	6.25	Gbps	
VDD Voltage	3.0	3.3	3.6	V	
EO-ACT H Voltage	1.0	-	VDD Voltage	V	
EO-DATA Common Voltage	0			V	Internal AC Coupling
EO-DATA Differential Voltage	200	-	1400	mVp	
OE-SDn H Voltage	3.0	-	VDD Voltage	V	
ANDATA Voltage	40			mV	
OE-DATA Common Voltage	0			mV	Internal AC Coupling
OE-DATA Differential Voltage	160	-	330	mVp	

## Pin Assignment and Explanation

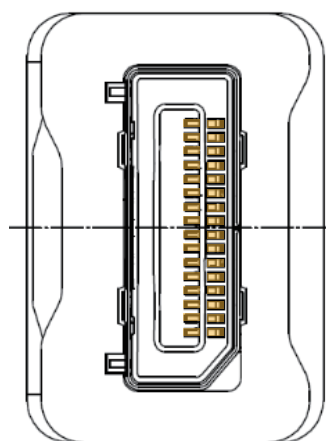

1 : VDD  
 2 : VDD  
 3 : GRN-LEDn  
 4 : OE-SDn  
 5 : VANDATA  
 6 : GND  
 7 : OE-DATA-  
 8 : OE-DATA+  
 9 : GND  
 10 : EO-DATA-  
 11 : EO-DATA+  
 12 : GND  
 13 : EO-ACT  
 14 : EO-ACTn  
 15 : AMB-LEDn  
 16 : NC

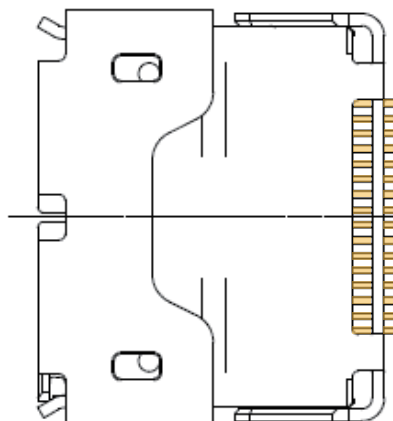

1 : VDD  
 2 : VDD  
 3 : GRN-LEDn  
 4 : OE-SDn  
 5 : VANDATA  
 6 : GND  
 7 : OE-DATA-  
 8 : OE-DATA+  
 9 : GND  
 10 : EO-DATA-  
 11 : EO-DATA+  
 12 : GND  
 13 : EO-ACT  
 14 : EO-ACTn  
 15 : AMB-LEDn  
 16 : NC

Pin No.	Pin Name	Type	Function
1	VDD	Power	BF4 Power Supply (3.3V DC)
2	VDD	Power	BF4 Power Supply (3.3V DC)
3	GRN-LEDn	Input	Green LED Emission Control 0V: On, 3.3V: Off
4	OE-SDn	Output	Signal Detection Pin 0V: Detection 3.3V: No Detection
5	ANDATA	Output	PD Current Monitor Pin [Output Voltage Value: monx2k Ω]
6	GND	GND	Ground
7	OE-DATA-	Output	SLVS Output
8	OE-DATA+	Output	
9	GND	GND	Ground
10	EO-DATA-	Input	SLVS Input
11	EO-DATA+	Input	
12	GND	GND	Ground
13	EO-ACT	Input	Transmitter Mode Switching 3.3V:Active 0V:Sleep
14	EO-ACTn	Output	ACT Detection Pin 0V:Detection 3.3V:No Detection
15	AMB-LEDn	Input	Amber LED Emission Control 0V: On, 3.3V: Off
16	N.C.	N.C.	Not Connected in Normal Operation

\*The I/O notation (Type) in the table above is the direction as seen from the BF4-IR2 plug.

## Materials

	Component	Material
IR2 Plug	Housing	PBT (Black)
	Printed Circuit Board	FR-4
	BF4-TX-14DS-0.5V	Print Circuit Board Mounting (Note 1)
	BF4-RX-14DS-0.5V	Print Circuit Board Mounting (Note 1)
	Insulation Case	PA
	Lock Bracket	Stainless Alloy
	Contact	Copper Alloy
	Shell	Stainless Alloy
	Cable Clamper	Copper Alloy
	Caulking	Aluminum Alloy
	Heat Shrink Tube	Polyolefin
	Light Guide Plate	PC
	Boots	Polyester Elastomer (Blue)
Duplex LC Plug	Housing	PEI (Beige)
	Extender Cap	PEI (Beige), Aluminum Alloy
	LC Ferrule	Zirconia, Copper Alloy
	Spring	Stainless Alloy
	Side Clip	PP (Beige)
	Boots	Polyester Elastomer (Blue)
	Boots Holder	Copper Alloy
	Cable Clamper	Copper Alloy
	Clamp Ring	Copper Alloy
	Heat Shrink Tube	Polyolefin (Black)
	Cap	Polyester Elastomer (Black)
Optical Fiber Cord	BF4MC-6GTXP-1	(Note 1)
	BF4MC-6GRXP-1	(Note 1)
	Blindfold	Copper Alloy
	Securing Ring	Copper Alloy
	Optical Fiber Cord	Configuration Listed Below (Note 2)
	-Optical Fiber Cord	Quartz Fiber (GI50/80)
	-Primary Coating	UV-Curable Resin
	-Secondary Coating	Thermoplastic Resin
	-Tension Member	Aramid Fiber (Kevlar)
	-Outer Jacket	PVC (Orange)
IR2 Receptacle	Insulation Case	PA
	Contact	Copper Alloy
	Shell	Stainless Alloy

Note 1 : Refer to the BF4MC Design Notes (ETAD-K0671) for information on the BF4MC plug harness/receptacle.

Note 2 : Optical fiber cable jackets contain dibutyltin compounds (DBT) intentionally added as catalysts below the REACH regulation value (1000ppm tin equivalent)

## Product Number Structure

Refer to the chart below when determining the product specifications from the product number.  
Please select from the product numbers listed in this catalog when placing orders.

### ● Plug Harness

#### **BF4-IR2 IR2 - 01 - # M**

①      ②      ③      ④      ⑤

① Series Name Type of Plug Attached to End of Harness 1	BF4-IR2 : BF4-IR2 Plug	④ Cable Length Specification	# : Cable Length
② Type of Plug Attached to End of Harness 2	IR2 : BF4-IR2 Plug LCD : Duplex LC Plug	⑤ Cable Length Measurement	M : Meter
③ Optical Cable Used	01 : SWCC GI50/80 x 2pos., φ 2		

### ● Receptacle

#### **BF4-IR2 - 16P - 0.5 SH (##)**

①      ②      ③      ④      ⑤

① Series Name	BF4-IR2	④ Mating Method	SMT Mated Horizontally Type
② Number of Pins	16 Pins	⑤ Product specifications (packing, etc.)	None : 150pcs per reel (01) : 10pcs per bag
③ Contact Pitch	0.5mm Pitch		

## Plug Variations



IR2-IR2

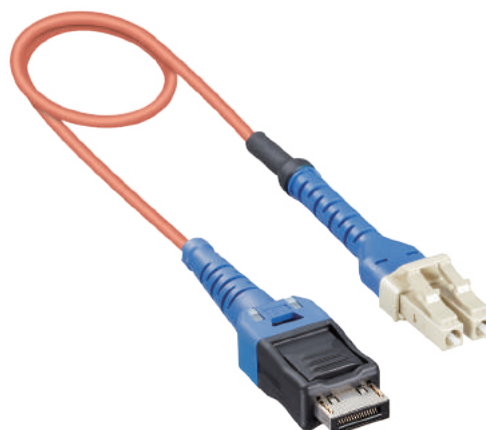

IR2-2 Core LC

## Connection Example

### Design Points

- 1: The +3.3V supplied to BF4-IR2 should be a low noise power supply made of linear regulators or LDO.
- 2: Route the Serdes (Serializer/Deserializer) to the BF4-IR2 receptacle with a differential impedance of 100Ω.
- 3: If the Deserializer (Differential EQ) does not have an internal terminator resistor, mount an external terminator resistor of 100Ω adjacent to the EQ input.
- 4: If an analog signal cannot be received by the Control IC, convert it to a digital signal with the AD converter (ADC) because the ANDATA signal is analog.
- 5: The OE-SDn signal is undefined when the BF4-IR2 receptacle is not inserted into the plug. Connect to the power supply with 10kΩ on the board. (10kΩ Pull-up)
- 6: Connect the BF4-IR2 internal plug LED (Amber) to the Control IC for lighting control. Short connection between EO-ACTn and AMB-LEDn is recommended when not controlling the LED.
- 7: Connect the BF4-IR2 internal plug LED (Green) to the Control IC for lighting control. Short connection between OE-SDn and GRN-LEDn is recommended when not controlling the LED.
- 8: It is recommended to use an inductor or ferrite bead for connection to GND as a measure to prevent noise from flowing in from FG.

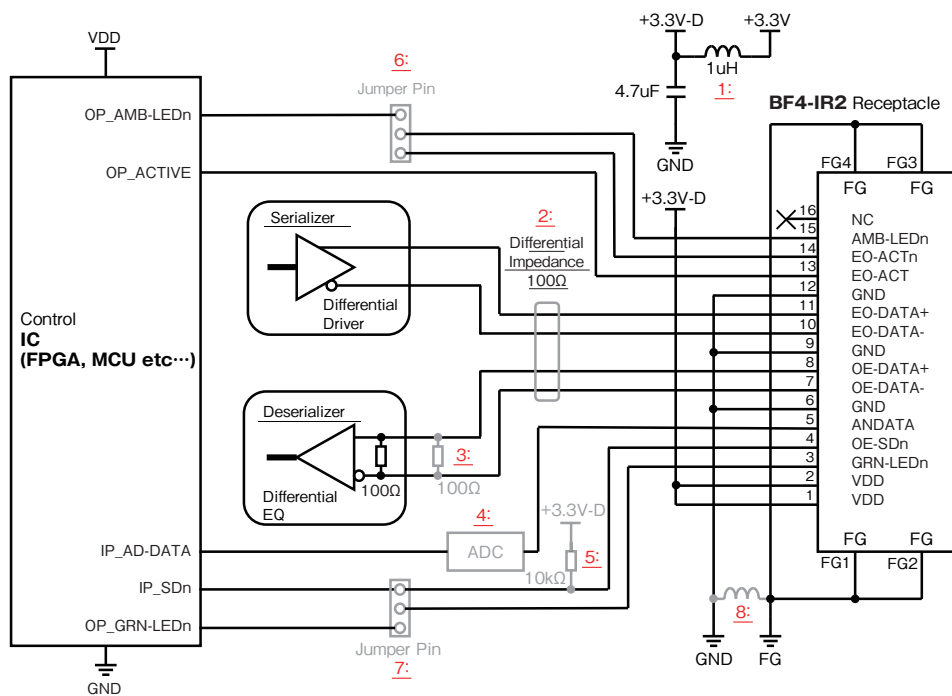

Receptacle Connection Example (Internal Board Connection)



## Plug Harness

- Double-Ended IR2 (IR2-IR2) Plug

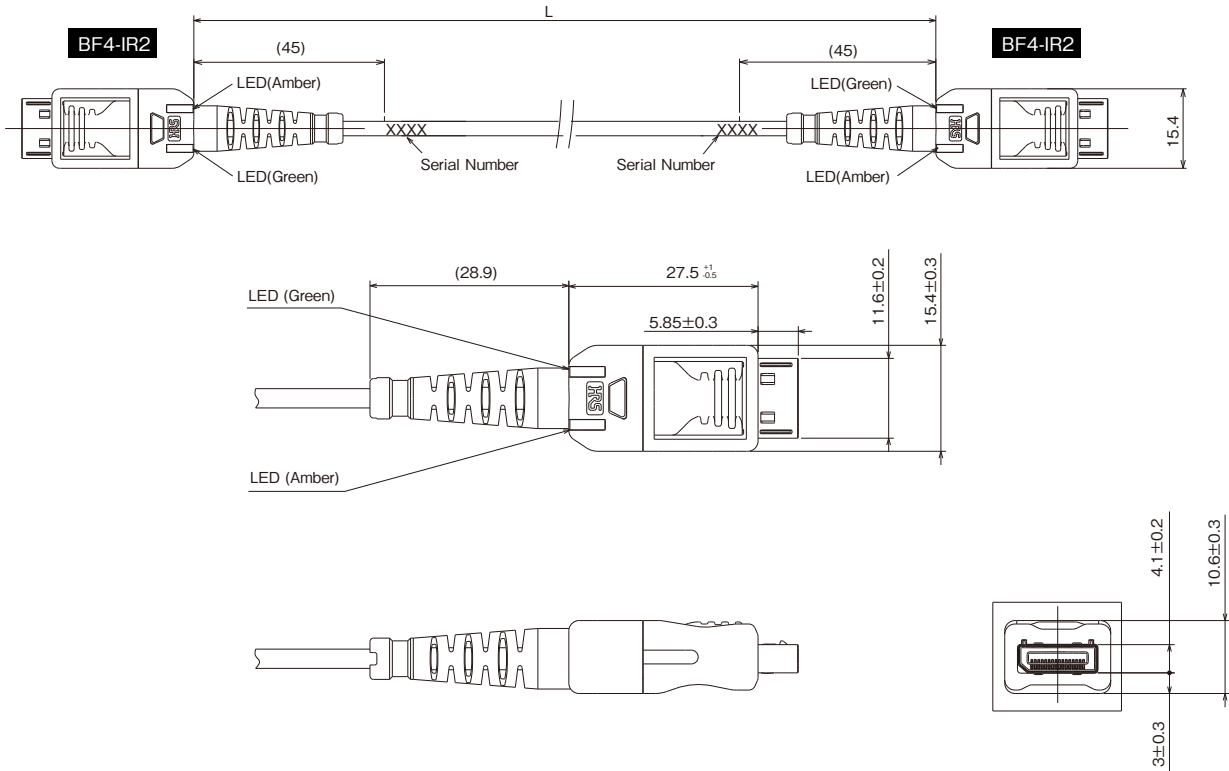
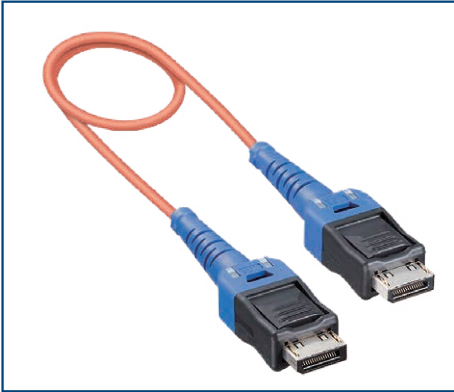

Representative Product Name for Double-Ended IR2 Plug Harness

Part No.	HRS No.	Cable Length
BF4-IR2IR2-01-1M	CL0831-1272-0-00	1m
BF4-IR2IR2-01-2M	CL0831-1274-0-00	2m
BF4-IR2IR2-01-3M	CL0831-1275-0-00	3m
BF4-IR2IR2-01-4M	CL0831-1276-0-00	4m
BF4-IR2IR2-01-5M	CL0831-1277-0-00	5m

### ● One-End Optical Connector LCD (IR2-Duplex LC) Plug

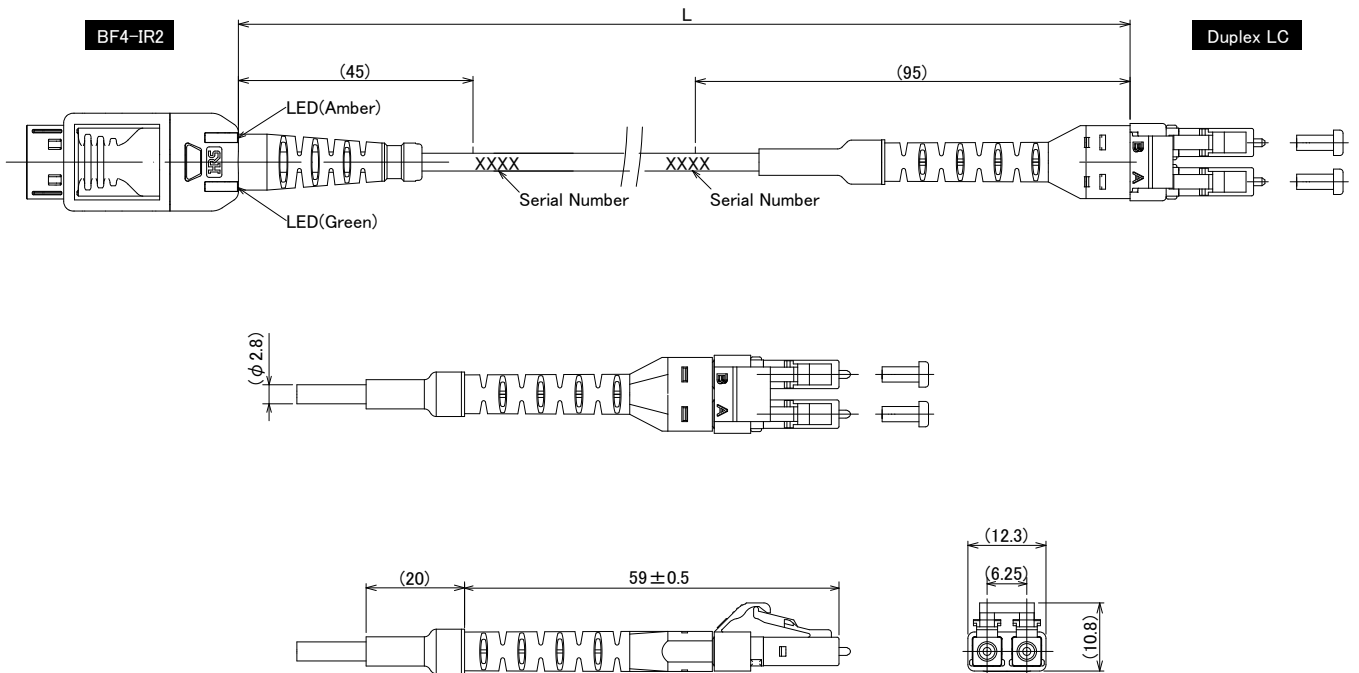
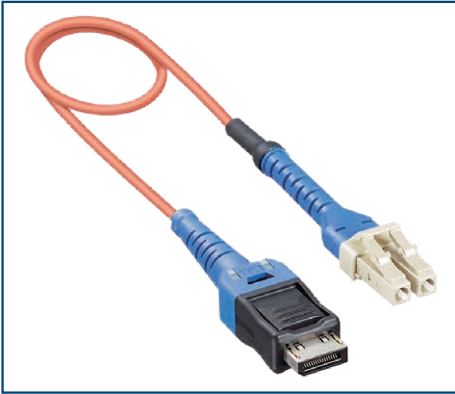

Representative Product Name for One-Ended LCD Plug Harness

Part No.	HRS No.	Cable Length
BF4-IR2LCD-01-1M	CL0831-1273-0-00	1m
BF4-IR2LCD-01-2M	CL0831-1282-0-00	2m
BF4-IR2LCD-01-3M	CL0831-1283-0-00	3m
BF4-IR2LCD-01-4M	CL0831-1284-0-00	4m
BF4-IR2LCD-01-5M	CL0831-1285-0-00	5m

## Receptacle

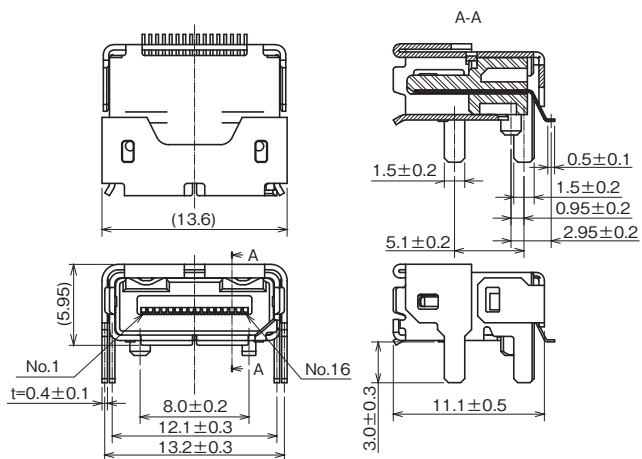

Part No.	HRS No.	Purchase Unit
BF4-IR2-16P-0.5SH	CL0831-1020-0-00	150pcs per reel
BF4-IR2-16P-0.5SH(01)	CL0831-1020-0-01	10pcs per bag

### ● Recommended Land Pattern

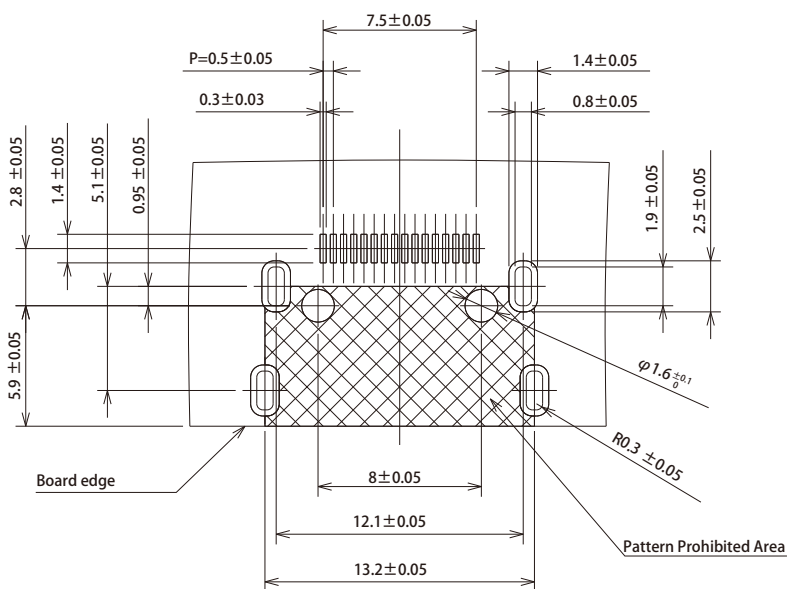

### ● Recommended Metal Mask Dimensions

(Recommended Metal Mask Dimensions: 120 μm)

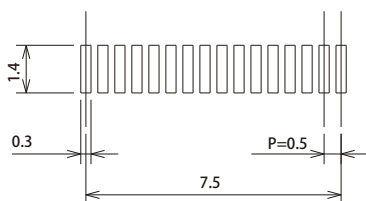

# Receptacle Packaging (Reel, Pack and Embossed Carrier)

## Reel and Dimensions

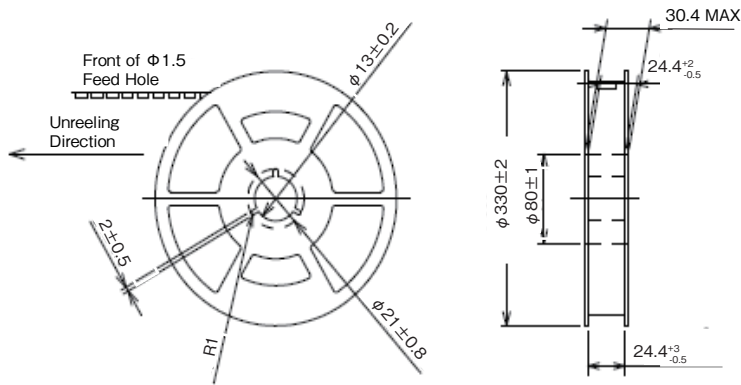

## Pack

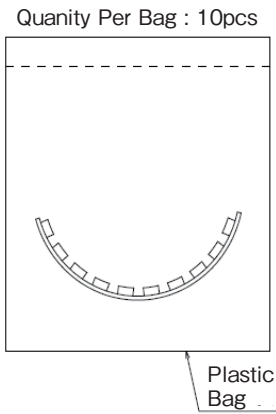

## Taping Direction

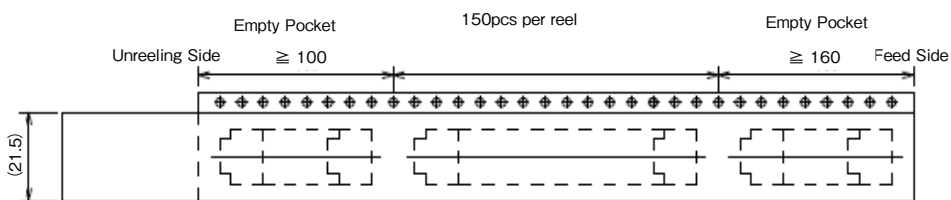

## Emboss Carrier Tape Dimensions

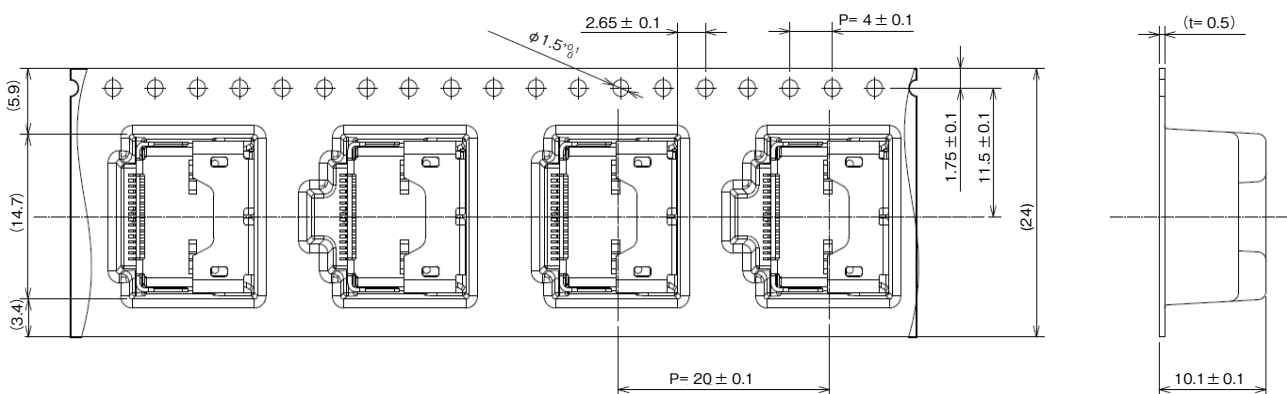

## Recommended Reflow Temperature Profile (Lead-Free Solder)

Recommended Reflow Conditions  
Temperature Profile  
(Lead Free Solder)

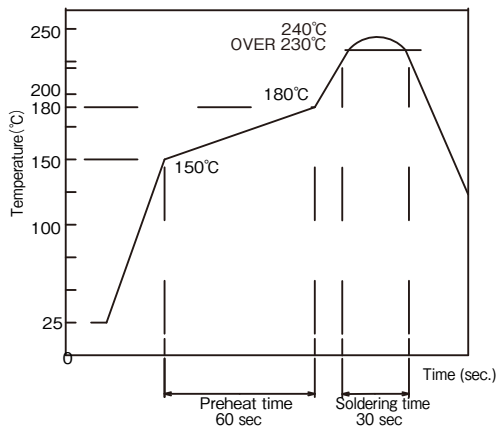

Recommended Reflow Conditions  
Temperature Profile  
(Connector Top Surface)

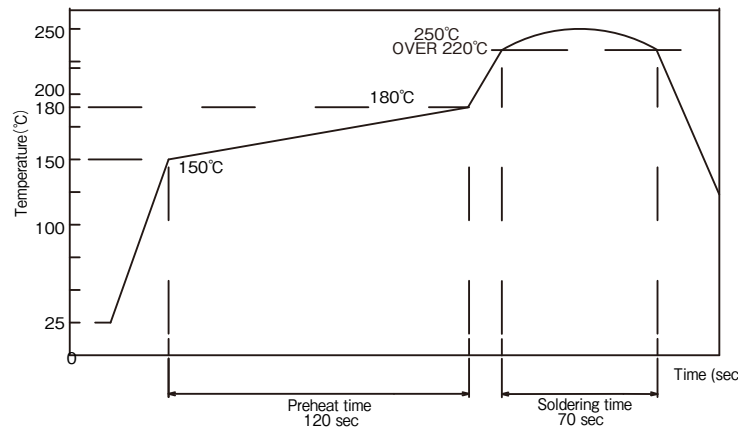

## Test Board

### BF4-IR2 High Speed Transmission Board

A test board is available to evaluate the operating characteristics of the plug harness.

\*Two pairs are required for evaluation. Contact a Hirose representative for details.

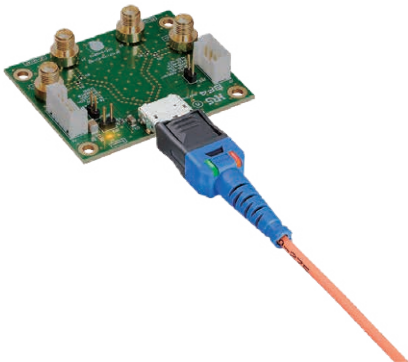

## Connector Mating/Removal Method

### ● Connector Mating Method

---

- Do not hold the optical fiber cable or cable securing section when mating. Hold the IR2 / LCD plug when mating. Holding the optical fiber cable or cable securing section may cause an excessive load resulting in damage.
- Do not mate while the power is on.  
IR2 Plug : Insert and remove the IR2 plug with the power turned off. Hot swap insertion or removal can cause damage.  
LCD Plug : Insert and remove the LCD plug with the power turned off. (Refer to "Notes on the laser" below on Notes on Product Usage.)
- Do not touch the tip of the mating part of the LCD plug directly.
- Plug Mating Durability  
IR2 Plug : The mating durability of the IR2 plug and IR2 receptacle is 1,000 times Max.  
LCD Plug : The mating durability of the LCD plug and LC adapter is 100 times Max.

### ● Connector Removal Method

---

- Remove the plug by pushing on the IR2 / LCD plug lock (unlock).  
Removal by holding the plug body without pushing on the lock or by holding the optical fiber cable or cable securing section can cause an excessive load resulting in damage.
- Do not remove the product while the power is on.  
IR2 Plug : Insert and remove the IR2 plug with the power turned off. Hot swap insertion or removal can cause damage.  
LCD Plug : Insert and remove the LCD plug with the power turned off. (Refer to "Notes on the laser" below on Notes on Product Usage.)

## Precautions

This product uses optical fibers for the transmission medium.

Optical fibers require more careful handling than similarly sized wires.

Additionally, the plug has a built in semiconductor chip (optical module) and requires caution with static electricity.

\* For details refer to the BF4-IR2 Series Design Note, ETAD-K0794.

For details on BF4MC inside the IR2 plug, refer to our BF4M Series Design Note, ETAD-0671.

### Notes on Product Handling

---

#### (Prohibition of Reproduction)

No part of this document may be copied or reproduced without prior written consent of Hirose Electric Co., Ltd.

(hereafter, Hirose). Even if written consent of Hirose is obtained, it is prohibited to amend any part of this document and copy or reproduce it.

Hirose shall assume no obligation or liability in connection with such amended information or reproduction.

#### (Responsibilities for Design Safety)

Hirose shall assume no responsibilities for the support for the application of the Product or the product design of the customer. The customer shall bear the responsibility of the Product and the application in which it used. The customer shall take appropriate design and operational safety measures in order to minimize the potential risks predicted for the product and application of the customer in which the Product is used.

#### (Responsibilities for Suitability Determination)

When using the Product, it is the customer's responsibility to ensure a safe design so that malfunction or failure of the Product would never cause an infringement on life, body or property. For design or use of the Product, make sure to refer to the materials (including the catalog, specifications, and design note) and follow the same. When using information including the product data provided in the document, technical data or circuit examples shown in the figures and tables, it is the responsibility of the customer to evaluate the information of the customer's product and determine the suitability for the Product.

#### (Responsibilities for Specific Applications)

Make sure to consult with a Hirose representative in advance when considering use for specific applications that require extremely high quality and reliability (e. g. nuclear equipment, aerospace systems, transportation equipment and various safety related equipment).

#### (Prohibition of Product Replication)

Do not disassemble, reverse-engineer, modify, analyze or replicate the Product.

#### (Prohibited Applications)

The Product must not be used for any application or product in which the manufacturing, use or sale is prohibited by domestic or international laws, regulations and ordinances.

#### (Notes on Warranty and License)

The technical data provided in the materials on the Product is intended to describe the representative behaviors and applied operations of the Product. It is not to guarantee the intellectual property rights or any other rights of Hirose nor a third party and not to grant the license.

#### (Notes on Contract Warranties)

Unless otherwise provided in a written contract or other documents (specifications) agreed between the customer and Hirose, Hirose makes no warranties of any kind (including, but not limited to, warranties of the function and operation, warranties of merchantability, warranties of suitability for a specific application or purpose and warranties on information accuracy).

#### (Notes on Export)

To export the Product to other countries, the exporter shall conduct the applicability determination based on the Foreign Exchange and Foreign Trade Act of Japan. If you wish to have the applicability determination sheet issued by Hirose, contact a sales representative. Note that in the export arrangement, the customer shall be the exporter and is required to comply with all applicable laws, regulations and Hirose's Terms of Conditions.

## Notes on Product Usage

---

### (Notes on the Specification Range)

Using the Product under conditions beyond the specification range (for voltage, current and temperature) provided in this document may result in an accident (including ignition, heat generation, and smoke generation). Confirm the document thoroughly and make sure to use the Product within the specification range.

### (Notes on the laser)

The laser beam is emitted from the end-face of the optical fiber in operation. It may cause eye injury or loss of sight if it enters the eyes. Do not stare directly into the end-face of the optical fiber. The laser beam is emitted from the VCSEL in operation. It may not be visible depending on its wavelength, but nonetheless it may cause eye injury or loss of sight if the laser beam or its reflected beam enters the eyes. Do not stare at or look into the laser beam directly.

### (Notes on use of GaAs)

The Product is equipped with a semiconductor within the connector and contains gallium arsenide (GaAs). GaAs powder and vapor are harmful to the environment and human body, so please take the following precautions.

- The following disposal methods are recommended.
- Entrusting a processor to collect, transport and treat arsenic substances.
- Separate special industrial waste from general industrial waste/household waste and manage until final disposal.

### (Notes on Waterproofing)

This product is not waterproof. Hirose does not guarantee quality in cases of condensation or wetting. Please perform waterproof treatment if condensation or wetting occurs.

### (Notes on Chemical Usage)

Do not use this product in an environment when acidic or alkaline chemicals are used. Direct use on products may cause deterioration and impact its properties.

### (Notes on the Environment including Gases)

Avoid the use of the Product in gas environments with chlorides or sulfides. The Product may deteriorate and features may be affected.

### (Notes on Storage)

Store the Product out of corrosive substances, corrosive gases, high temperature and humidity or direct sunlight. Do not apply excessive pressure or vibration to the Product. It may cause deterioration, deformation, damage or failure of the Product.

### (Notes on Resin Molded Part)

The resin molded part of the Product may contain black spots or its color may differ slightly, but that has no effect on the product performance.

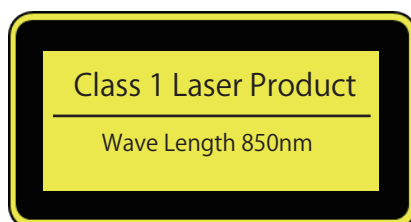



## While Taking into Consideration

Specifications mentioned in this catalog are reference values.

When considering to order or use this product, please confirm the Drawing and Product Specifications sheets.

Use an appropriate cable when using the connector in combination with cables.

If considering usage of a non-specified cable, please contact your sales representative.

If assembly process is done by jigs & tools which are not identified by Hirose, assurance will not be given.

If considering usage for below mentioned applications, please contact your sales representative.

In cases where the application will demand a high level of reliability, such as automotive, medical instruments, public infrastructure, aerospace/ defense etc. Hirose must review before assurance of reliability can be given.